

GPA-25

Palletizing robot

with fork gripper / graphics

6-axis-robot for dynamic palletizing and depalletizing on up to 2 pallets

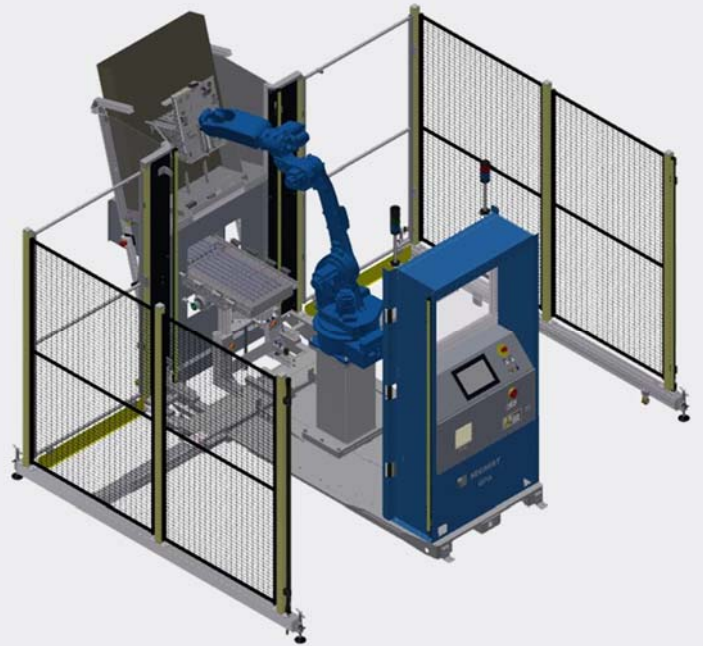

Technical Specifications

Products		Open cardboard boxes, boxes, trays, and loose products such as paper stacks, magazines and other packages
System		6-axis-robot
Product width	max.	260 mm
	min.	150 mm
Product length	max.	380 mm, back length, with slip sheet, without slip sheet also longer
	min.	150 mm
Product height	max.	230 mm
	min.	35 mm
Load capacity	max.	9 kg*
Pallet formats		800 x 1200 mm, 1000 x 1200 mm, 40 x 48", 1165 x 1165 mm, 45 x 45" (other pallet formats possible)
Pallet height	max.	1600 mm, incl. pallet (euro pallet)*
Empty pallet height		140 mm (min.) – 160 mm (max.)
Speed	max.	6 cycles/min.*
Drive		6 controlled Servo axes
Voltage		3 x 380 – 440 VAC, 50/60 Hz
Power consumption	approx.	3 kVA
Fuse		3 x 16 A, slow-blow fuse
Air pressure	min.	6 bar
Air consumption		depending on gripping device
Control		IPC with RobAdmin palletizing program as a configuration interface for setting the package and pallet sizes and the layer patterns

*The data given is interdependent with product dimensions, pallet format, pallet height, speed, gripping tool, column height and number of slip sheets.

Color scheme as shown (see above).

SEGBERT

PALLETIZING & AUTOMATION

Gutenbergstraße 16
D-48683 Ahaus

Telefon +49 (0) 25 61/95 04-0
Telefax +49 (0) 25 61/95 04-20
Mail segbert@segbert.com

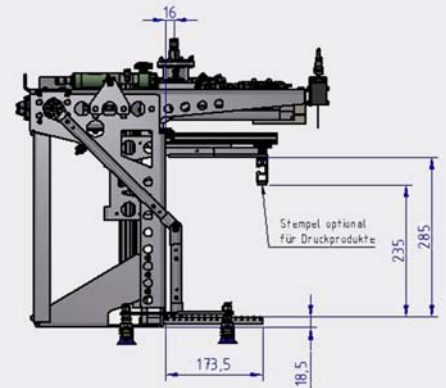
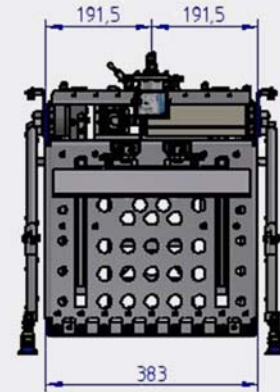
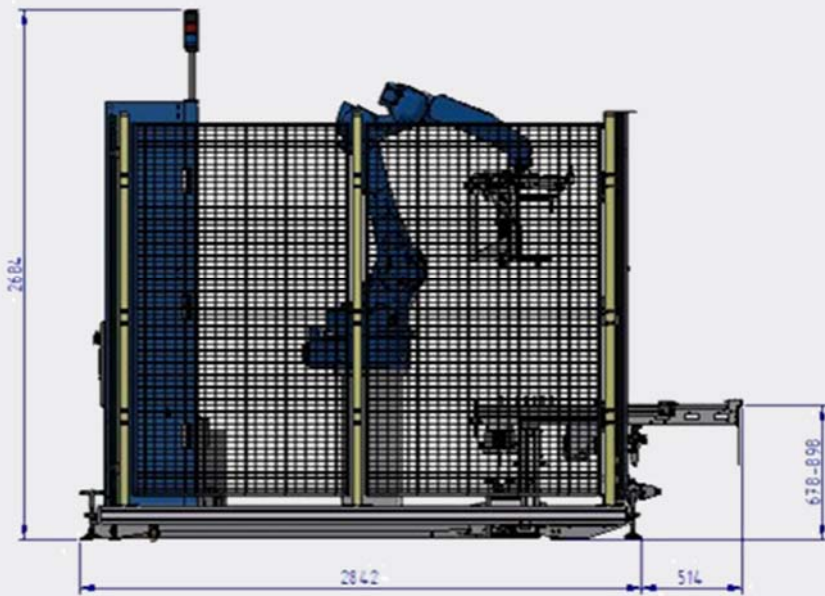

Transport dimensions

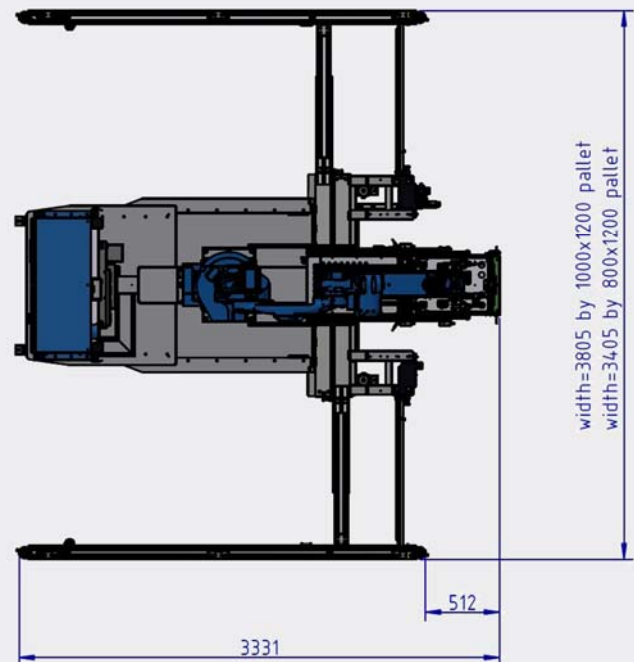
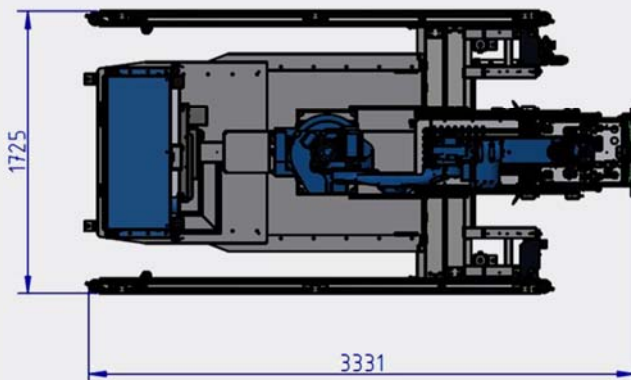

Volksbank Gronau Ahaus eG IBAN: DE33 4016 4024 0602 0192 00 BIC: GENODEM1GRN

Sitz der Gesellschaft: Ahaus Registergericht: Coesfeld, HRA 2048 UStID.: DE123700344 Steuernummer: 301/5750/0035
Komplementär: Segbert Verwaltungsgesellschaft mbH Sitz: Ahaus Registergericht: Coesfeld, HRB 4251
Geschäftsführer: Klaus Segbert